

# CuB Series Gas-Fired, Wall Hung Modulating Hot Water Boiler

**[ Available in both Combi &  
Space Heating-Only models ]**

- ▶ 85% AFUE efficiency
- ▶ Inducer fan and gas valve modulate for operation between 33% and 100% of capacity for fuel economy
- ▶ Chimney or Horizontal Vent
- ▶ Advanced Controls - Digital Display with temperature indication, diagnostics and status symbols showing: Heating mode, Burner On and Burner Modulation Level
- ▶ Durable Lightweight One Piece Steel Jacket
- ▶ 10-Year Limited Copper Heat Exchanger Warranty
- ▶ 2-Year Limited Parts Warranty

## **Combination (Combi) - Heating and Domestic Hot Water (Model CCB-150)**

- ▶ Available in 150 MBH
- ▶ Advanced Controls - additional DHW mode
- ▶ Stainless Steel Brazed Plate Heat Exchanger for potable domestic hot water

## **Space Heating-Only (Models CHB-100, CHB-130 & CHB-150)**

- ▶ Available in 3 sizes: 100, 130 and 150 MBH
- ▶ Dedicated DWH connections for adding an Indirect Water Heater

**Shown with  
optional  
floor base**

**Labor Saver™ Manifold  
INCLUDED**



## Simple...

### Modern doesn't mean complicated...

Some of the best ideas actually are pretty simple, like the new Utica CuB. The CuB Series is a "best of both worlds" alternative to large conventional cast iron boilers and more expensive wall hung condensing boilers. CuB saves on living space, is lightweight and wall hung.

The Utica CuB Series is ideal for both heating only and "combi" or combination heating and domestic hot water applications including:

- Single Family Homes
- Apartments/Multi-Family Dwellings with Individual Appliances
- Retro-fits for High Temperature Systems



The CuB's special copper heat exchanger design with a protective high temperature coating ensures years of reliable operation. The CuB is much smaller and lighter yet transfers heat seven times faster than cast iron.

**Copper makes the CuB a compact, lightweight unit that saves valuable space and protects the boiler from basement flooding by getting it up off the floor. If wall mounting is not practical, an optional floor base is available.**

## Economical...

### Modulation –

The CuB's advanced control system gives you what you want when you need it. Your heating systems' boiler is sized to keep you warm during the coldest days of the year. But in the summer months all that fuel is not required to keep you warm and comfortable. The CuB's advanced modulating control system measures how much fuel is required based on load conditions (how cold it is outside) and delivers only what is needed. This is modulation and it burns less fuel, saves you money and is good for the environment.

The CuB boiler is 85% efficient, however the actual efficiency of a boiler is dependent upon the heating system it is matched with. If your home was designed

to minimize the amount of heat emitters (baseboard, radiators etc.) then it was likely designed to run at high temperature water supply which is ideal for a non-condensing boiler.

Conversely, if your home was designed for maximum heat emitters, then it was designed to operate at low temperature water supply and should be matched with a condensing boiler like the Utica SSC 95% model to maximize efficiency. Make sure to consult with your professional contractor to match the right boiler to your heating system to maximize efficiency and make the best choice for your home.

## Dependable...

The CuB Series features proven copper heat exchanger technology that has been in use for decades and reliable direct spark ignition. Utica's quality construction is backed by a full 10 year limited copper heat exchanger warranty and a 2-year limited parts warranty.

The CuB is a simple, economical, dependable approach to residential heat and domestic hot water.



CuB Series

**CuB Combi Unit (CCB-150)**

**FRONT OF BOILER**

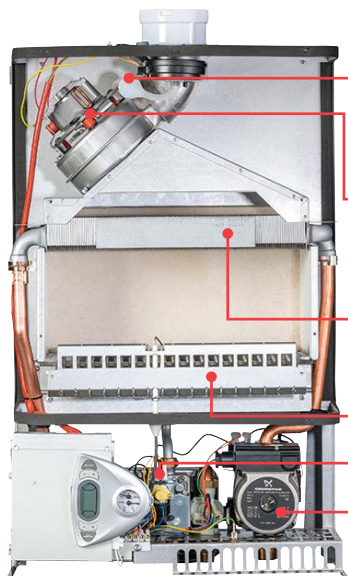

- Cold Climate Operation**  
Condensate collector keeps condensation from impacting the pressure switch operation.
- Modulating Fan With Air Pressure Sensor**  
Automatically adjusts the fan speed according to the flue draft.
- Copper Heat Exchanger**  
Features high temperature corrosion resistant protective film.
- Stainless Steel Burners**
- Modulating Gas Valve**
- 3-Speed Pump with Anti-Seize**  
Every 24 hours, pump will run for 5 seconds.

**BACK OF BOILER**

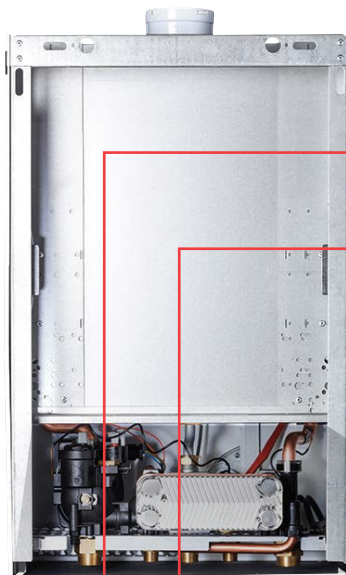

- Air Vent**  
Integrated in the pump block.
- 24-Volt Diverting Valve- Priority for Domestic Hot Water**
- DHW Stainless Steel Brazed Plate Heat Exchanger**

**CONTROL DISPLAY**

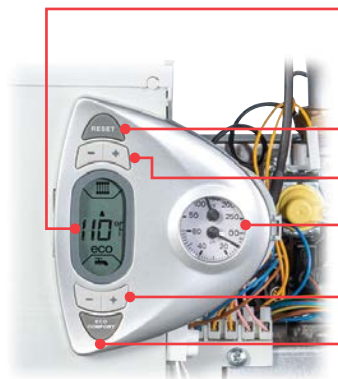

- LCD Display**
  - DHW Request
  - CH Request
  - Operating Temp.
  - Eco/Comfort
  - Burner On
  - Burner Power
- Reset**
- Central Heating Settings**
- Water Pressure and Temperature Gauge**
- Domestic Hot Water Settings**
- ON/OFF and Comfort Mode Key**

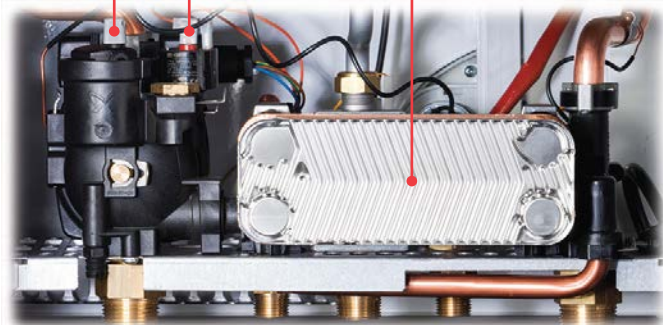

**TOP OF BOILER**

**Air Intake**  
2 Alternate Locations

**Flue Exhaust**

**Boiler Venting Options**  
Category I – Chimney Venting  
Category III – Sidewall



**BOTTOM OF BOILER**

**3/4" DHW Out**    **3/4" Gas**    **3/4" DHW In**  
**1" CH Supply**    **1" CH Return**

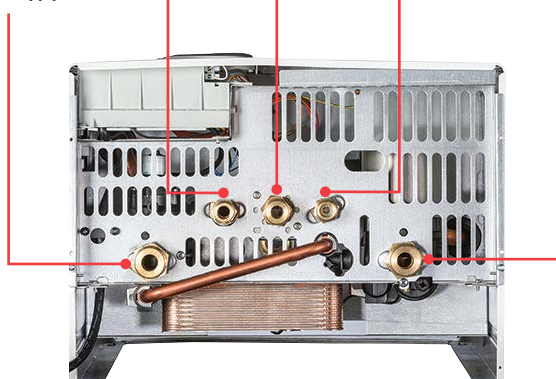

# Utica CuB Series Gas-Fired Hot Water Boiler

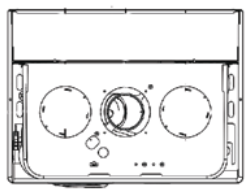
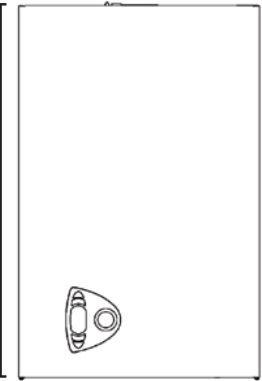
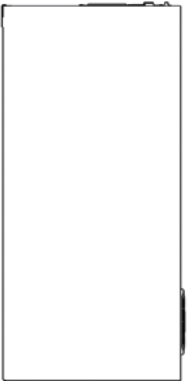
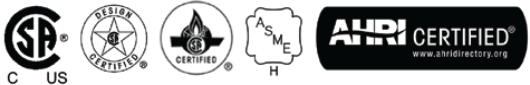
| Dimensional Diagram  | Model  | Input Rate (MBH) <sup>(1)</sup>  | Heating Capacity (MBH) <sup>(1)(2)</sup> | Net AHRI Rating, Water (MBH) <sup>(1)(3)</sup> | Vent Diameter                          |                                 | AFUE % <sup>(2)</sup> |
|--|--|--|--|--|--|---------------------------------|-----------------------|
|  |  |  |  |  | To Chimney <sup>(4)</sup> (Category I) | Horizontal Vent* (Category III) |                       |
| <p>CCB-150 / CHB-150 Shown</p> <p>See IOM for dimensions on other models.</p> <p><b>TOP</b></p> <p>Width 17-23/32"</p>  <p><b>FRONT</b></p> <p>Height 27-9/16"</p>  <p><b>SIDE</b></p> <p>Depth 13"</p>  | CCB-150  | 150  | 127                                      | 110  | 4"                                     | 3"                              | 85                    |
|  | CHB-150  | 150  | 130                                      | 110  | 4"                                     | 3"                              | 85                    |
|  | CHB-130  | 130  | 110                                      | 96   | 4"                                     | 3"                              | 85                    |
|  | CHB-100  | 100  | 85                                       | 73   | 4"                                     | 3"                              | 85                    |
| *Horizontal Venting requires field supplied appliance adapter for the boiler flue outlet.  |  |  |  |  |  |                                 |                       |
| (1) 1000 Btu/hr (British Thermal Units Per Hour)   |  |  |  |  |  |                                 |                       |
| (2) Heating Capacity and AFUE (Annual Fuel Utilization Efficiency) are based on DOE (Department of Energy) test procedures.  |  |  |  |  |  |                                 |                       |
| (3) Net AHRI Water Ratings shown based on piping and pickup allowance of 1.15. Consult manufacturer before selecting boiler for installations having unusual piping and pickup requirements, such as intermittent system operation, extensive piping systems, etc.   |  |  |  |  |  |                                 |                       |
| (4) Boiler is provided with a 3" vent connection. a 3"x4" increaser must be field supplied for chimney vent applications. This does not infer that the connection to the chimney will always be 4". Please refer to IOM, National Fuel Gas Code, ANSI Z223.1/NFPA54, or applicable provisions of the local building codes for details concerning proper chimney connections.   |  |  |  |  |  |                                 |                       |
| <b>General Information</b> (See Installation, Operation and Maintenance Manual for complete instructions)  |  |  |  |  |  |                                 |                       |
| <p><b>Clearances</b></p> <p>(4) Required distances measured from boiler jacket.</p> <p>(5) Service, proper operation clearance recommendation.</p>   | <p><b>Top</b></p> <p><b>Left Side</b></p> <p><b>Right Side</b></p> <p><b>Front</b></p> <p><b>Back</b></p> <p><b>Bottom</b></p> <p><b>Combustion Air/Piping</b></p> <p><b>Vent Piping</b></p> | <p><b>Combustible Materials (Required) <sup>(4)</sup></b></p>  |  | <p><b>Service <sup>(4) (5)</sup></b></p>       |  |                                 |                       |
|  |  | 16" (41 cm)  |  | 16" (41 cm)                                    |  |                                 |                       |
|  |  | 0" (0 cm)  |  | 1" (3 cm)                                      |  |                                 |                       |
|  |  | 0" (0 cm)  |  | 1" (3 cm)                                      |  |                                 |                       |
|  |  | 0" (0 cm)  |  | 1" (3 cm)                                      |  |                                 |                       |
|  |  | 0" (0 cm)  |  | 0" (0 cm)                                      |  |                                 |                       |
|  |  | 0" (0 cm)  |  | 12" (30 cm)                                    |  |                                 |                       |
|  |  | 0" (0 cm)  |  | 3/8" (1 cm)                                    |  |                                 |                       |
|  |  | 6" (15 cm)   |  | 6" (15 cm)                                     |  |                                 |                       |
| <p><b>Connections CCB-150</b></p>  |  | Return/Supply Water 1", Gas In 3/4" NPT, Domestic Hot Water Inlet/Outlet 3/4" NPT  |  |  |  |                                 |                       |
| <p><b>Connections CHB-130 &amp; CHB-100</b></p>  |  | Return/Supply Water 1", Gas In 3/4" NPT, Indirect Tank 3/4" NPT  |  |  |  |                                 |                       |
| <p><b>Electrical</b></p>   |  | 120 Volts AC, 60 hertz, 1 phase, Less than 12 amps (15 amp circuit recommended)  |  |  |  |                                 |                       |
| <p><b>Water Content</b></p>  |  | CCB-150/CHB-150: .396 Gallons, CHB-130: .317 Gallons, CHB-100: .211 Gallons  |  |  |  |                                 |                       |
| <p><b>Dimensions/Weights</b></p>   | <p><b>Model</b></p>  | <p><b>Width</b></p>  | <p><b>Height</b></p>                     | <p><b>Depth</b></p>                            | <p><b>Weight</b></p>                   |                                 |                       |
|  | CCB-150/CHB-150  | 17-23/32"  | 27-9/16"                                 | 13"  | 78/73                                  |                                 |                       |
|  | CHB-130  | 15-3/4"  | 27-9/16"                                 | 13"  | 69                                     |                                 |                       |
|  | CHB-100  | 15-3/4"  | 27-9/16"                                 | 13"  | 65                                     |                                 |                       |
| <p><b>Standard Equipment</b></p>   |  | <p><b>Boiler Control Module:</b> High Limit/Electronic Ignition Control.<br/> <b>User Display Interface:</b> Digital Temperature Display with diagnostics and programmable settings.<br/> <b>Heat Exchanger:</b> Copper Fin Tube. (CCB-150 combination boiler includes a stainless steel brazed plate heat exchanger - 3.6 gpm at 70°F Temperature Rise, 6.3 gpm at 40°F Temperature Rise)<br/> <b>Valve:</b> 3-Way Water Diverting Valve.<br/> <b>Combustion:</b> Completely Installed and Wired Modulating Gas Control System (100% to 33%) with Stainless Steel Burners and Manifold consisting of: Automatic Modulating Gas Valve, Direct Spark Ignition Control, 100% Shut Off, Combination Spark Electrode/Flame Sensor.<br/> <b>Safety:</b> Pressure Switch (vent safety shutoff).<br/> <b>Other:</b> Primary/Secondary Manifold, Assembled Boiler with Jacket, Induced Draft Fan, Combination Temperature/Pressure Gauge, Circulator Pump, Gas Shut Off Valve and Field installed - 30lb. ASME Relief Valve.</p> |  |  |  |                                 |                       |
| <p><b>Options</b></p>  |  | Floor Base, LP Gas Conversion Kit, Horizontal Vent Termination Concentric Kit, Indirect Hot Water Tank Sensor, Outdoor Air Temperature Reset Sensor.   |  |  |  |                                 |                       |
| <p><b>Certifications</b></p>   |  |  <p>Tested for 43.5 psi. ASME Working Pressure</p>   |  |  |  |                                 |                       |



ECR International Inc. 2201 Dwyer Avenue, Utica, NY 13501  
 Tel. 800 253 7900  
[www.ecrinternational.com](http://www.ecrinternational.com)

All specifications subject to change without notice.  
 © 2019 ECR International, Inc.  
 PN 240010540 Rev. [8/19/2019]