

Honeywell

R8239 FAN CENTER OR AT72H,J TRANSFORMER (WITH APPROPRIATE RELAY) , PROVIDES LOW VOLTAGE CONTROL OF LINE VOLTAGE FAN MOTORS AND AUXILIARY CIRCUITS IN HEATING, COOLING, OR HEATING-COOLING SYSTEMS.

- AT72H,J Transformer provides for addition of cooling at later date without expensive re-wiring by simply plugging in an R8222 (3/4 hp) or an R8228 (1 hp) Switching Relay.
- Overload protection is provided for the transformer.
- Large 38 VA transformer to power heating-cooling low voltage control systems.
- Low voltage terminal board provides convenient connections for thermostat, and heating and cooling equipment control circuit wiring.
- Mounts on standard 4 inch square junction box.
- Relay in R8239 is mounted in a receptacle and can easily be replaced without disturbing wiring.
- R8239, with completely enclosed relay, can be mounted in any indoor location without additional enclosure.
- Meets NEMA ST2-1973 Standard "Residential Controls-Class 2 Transformers," marked "NEMA Type D."

R.E.
REV. 6-78 (.08)

FAN CENTERS

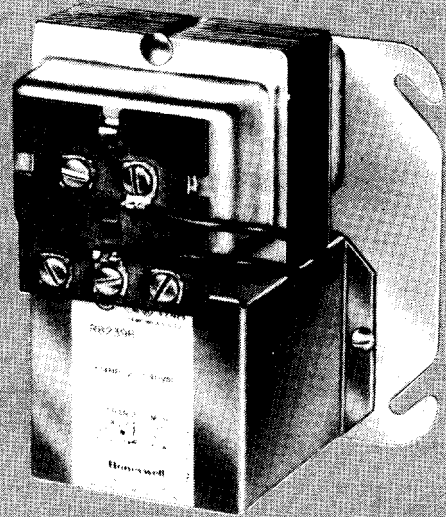

R8239A-H
AT72H,J
Q633A

Form Number

60-2023-7

SPECIFICATIONS

IMPORTANT

THE SPECIFICATIONS GIVEN IN THIS PUBLICATION DO NOT INCLUDE NORMAL MANUFACTURING TOLERANCES. THEREFORE, THIS UNIT MAY NOT MATCH THE LISTED SPECIFICATIONS EXACTLY. ALSO, THIS PRODUCT IS TESTED AND CALIBRATED UNDER CLOSELY CONTROLLED CONDITIONS, AND SOME MINOR DIFFERENCES IN PERFORMANCE CAN BE EXPECTED IF THOSE CONDITIONS ARE CHANGED.

TRADELINE MODELS

TRADELINE models are selected and packaged to provide ease of stocking, ease of handling and maximum replacement value. TRADE LINE model specifications are the same as standard models.

TRADELINE models:

R8239A Fan Center—spdt switching; 38 VA transformer. For single-speed or 2-speed fan application.

R8239B Fan Center—dpdt switching; 38 VA transformer. For “total comfort” application with electronic air cleaner, humidifier and blower motor.

R8239D Fan Center—dpst switching; 1 normally open power pole, and 1 normally open pilot duty pole; 38 VA transformer. For 1-speed fan application with an auxiliary circuit.

R8239G Fan Center—spst switching; normally open pole; 38 VA transformer. For 1-speed,

1 hp fan application.

R8239H Fan Center—spdt switching; 38 VA transformer. For 1- or 2-speed, 1 hp fan application.

Q633A1007 Plate Mounted Relay Receptacle—for installing R8222 and R8228 relays on J-boxes. Includes leadwires for dpdt relay, metal relay cover, and labels for spst, spdt, and dpdt relays. A knockout allows mounting a SUPER TRADELINE AT72D transformer. See Table 1 or TRADELINE Catalog to order appropriate relay.

ADDITIONAL FEATURES: TRADELINE pack with cross reference label and special instruction sheet.

STANDARD MODELS

TABLE I—R8239 MODEL SPECIFICATIONS

FAN CENTER	R8239 REPLACEMENT COMPONENTS ^a		RELAY HORSE-POWER	SWITCHING	INPUT VOLTAGE (V AC)	SEE WIRING DIAGRAM
	TRANSFORMER AND RECEPTACLE	RELAY				
R8239A	AT72H	R8222B	3/4	Spdt	120 or 208/240	Fig. 5
R8239B	AT72J	R8222D	3/4	Dpdt		Fig. 6
R8239C	AT72H	R8222A	3/4	Spst, N.O. Contact		Fig. 7
R8239D	AT72J	R8222U	3/4	Dpst, 1 N.O. Power Contact, 1 N.O. Pilot Duty Contact		Fig. 8
R8239E	AT 72J	R8222F	3/4	Dpst, 1 N.O. Contact, 1 N.C. Contact		Fig. 9
R8239F	AT72J	R8222C	3/4	Dpst, both Contacts N.O.		Fig. 8
R8239G	AT72H	R8228A	1 ^b	Spst, N.O. Contact		Fig. 7
R8239H	AT72H	R8228B	1 ^b	Spdt		Fig. 5

^aAT72H, J and appropriate relay can be ordered separately. ^b1 hp at 120V ac; 2 hp at 240V ac.

(continued on page 3)

ORDERING INFORMATION

WHEN PURCHASING REPLACEMENT AND MODERNIZATION PRODUCTS FROM YOUR TRADELINE WHOLESALE OR YOUR DISTRIBUTOR, REFER TO THE TRADE LINE CATALOG OR PRICE SHEETS FOR COMPLETE ORDERING NUMBER, OR SPECIFY-

1. Order number. 2. Transformer primary voltage. 3. Accessories, if required.

IF YOU HAVE ADDITIONAL QUESTIONS, NEED FURTHER INFORMATION, OR WOULD LIKE TO COMMENT ON OUR PRODUCTS OR SERVICES, PLEASE WRITE OR PHONE:

- YOUR LOCAL HONEYWELL RESIDENTIAL DIVISION SALES OFFICE (CHECK WHITE PAGES OF PHONE DIRECTORY).
- RESIDENTIAL DIVISION CUSTOMER SERVICE
HONEYWELL INC., 1885 DOUGLAS DRIVE NORTH
MI **NNEAPOLIS**, MINNESOTA 55422 (612) 542-7500

(IN CANADA—HONEYWELL CONTROLS LIMITED, 740 ELLESMERE ROAD, SCARBOROUGH, ONTARIO M1P 2V9)
INTERNATIONAL SALES AND SERVICE OFFICES IN ALL PRINCIPAL CITIES OF THE WORLD.

STANDARD MODELS:

AT72H Plate-mounted Transformer-Relay Receptacle –use when cooling will be added later. Includes receptacle and leadwires for spst or spdt relay circuit; less R8222 or R8228 relay and relay cover. See Table I to order appropriate relay.

AT72J Plate-mounted Transformer-Relay Receptacle–use when cooling will be added later. Includes receptacle and leadwires for dpdt or dpst relay circuit; less R8222 or R8228 relay and relay cover. See Table I to order appropriate relay.

TRANSFORMER RATINGS:

- Power Rating–38 VA.
- Primary Voltage–either 120 or 208/240V ac.
- Open Circuit Secondary Voltage –26 ± .5 volts.
- Overload Protection–Internal.
- Voltage Frequency–50/60 Hz.

CONTACT RATINGS: Contact ratings are for both normally open and normally closed contacts.

R8239A–F.

VOLTAGE	120V AC	240V AC
Full Load (amp)	13.8	6.9
Locked Rotor (amp)	82.8	41.4
Horsepower	3/4	3/4

R8239G and H.

VOLTAGE	120V AC	240V AC
Full Load (amp)	16	12
Locked Rotor (amp)	96	72
Horsepower	1	2

RELAY COIL RATINGS:

- Inrush –20 VA maximum.
- Sealed–9 VA.
- Wattage–5 watts.
- Pickup Voltage–must pick up below 18 volts.

LEADWIRE COLOR CODE:

MODEL	SWITCHING	POLE	LEADWIRE COLOR
R8239A AT72H	Spdt	—	Black–common Red–N.O. contact Brown–N.C. contact
R8239B AT72J	Dpdt	Pole 1	Black–common Red–N O. contact Brown–N.C. contact
		Pole 2	Violet–common Red/Yellow–N.O. contact Yellow–N.C. contact
R8239C	Spst	—	Both leadwires black–N.O. contact
R8239D	Dpst	Pole 1 (power pole)	Both leadwires black–N.O. contact
		Pole 2 (pilot duty pole)	Both leadwires red–N.O. contact
R8239E	Dpst	Pole 1	Both leadwires black–N.O. contact
		Pole 2	Both leadwires red–N.C. contact
R8239F	Dpst	Pole 1	Both leadwires black–N.O. contact
		Pole 2	Both leadwires red–N.O. contact
R8239G	Spst	—	Both leadwires black–N.O. contact
R8239H	Spdt	—	Black–common Red–N. O. contact Brown–N.C. contact

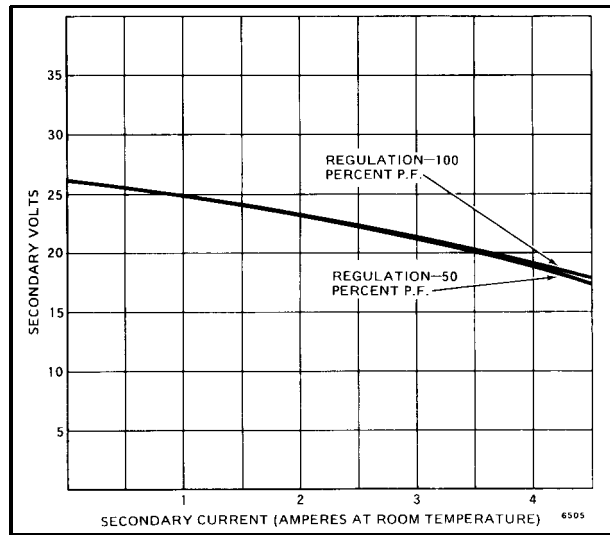

FIG. 1-38 38 VA TRANSFORMER REGULATION CURVES.

PILOT DUTY RATINGS FOR R8239D PILOT DUTY POLE:

- Minimum–3 VA at 24, 120, 240, and 480V ac.
- Maximum–25 VA at 24V ac, 125 VA at 120, 240, and 480V ac.
- Resistive–3 amps at 277V ac (0.75 power factor).
- Powerpile (millivoltage) –The normally open pilot duty contacts are rated for Powerpile (millivoltage) applications: 0.25 amp at 0.25 to 12V dc.

TRANSFORMER PRIMARY LEADWIRE COLOR CODE:

- 120V–Black and white.
- 208/240V–black–common: Red–208V.
Orange –240V.

LEADWIRES: 9 inch color-coded leadwires.
 RELAY COIL LEADWIRE COLOR CODE: 2 blue leads connected to "C" and "G" terminals.
 POWER CONSUMPTION: 7.0 watts maximum.
 CONTACTS: Silver cadmium oxide.
 MOUNTING: Mounts on standard 4 inch square junction box.
 DIMENSIONS: See Figs. 2 and 3.
 UNDERWRITERS LABORATORIES INC. LISTED (for R8239A-H): File No. E4436, Guide No. XAPX. (R8222A-H): File No. E59779, Guide No. NLDX2.
 CANADIAN STANDARDS ASSOCIATION COMPONENT RECOGNIZED:
 R8239A-H-File No. LR1620.
 R8222 (all models)- File No. LR35066.

EXTERNAL LOAD: R8239 and AT72H,J (with R8222 or R8228 relay) will operate the following typical Honeywell relay and/or contactor loads with up to 300 feet of No. 18 gauge wire (150 ft run). The maximum load for each application is:
 2-R8230 Switching Relays.
 2-R850 Contactors.
 1 -R8230 Switching Relay and one R850 Contactor.
 1 -R850 Contactor and one R8093 Thermal Delay Relay.
 1 -R8210, R8212, or R8214 Contactor and one R8230 Relay.
 1-R8210, R8212, or R8214 Contactor and one R8093 Thermal Delay Relay.

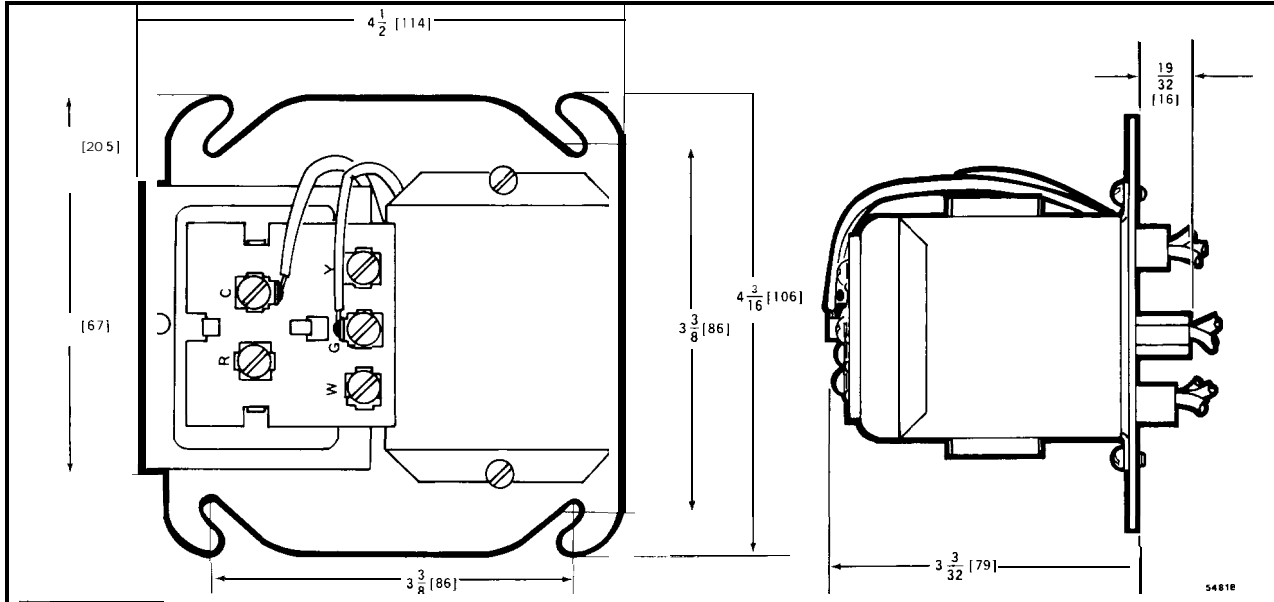

FIG. 2-APPROXIMATE R8239 AND AT72H WITH RELAY COVER INSTALLATION DIMENSIONS IN INCHES [MILLIMETRES].

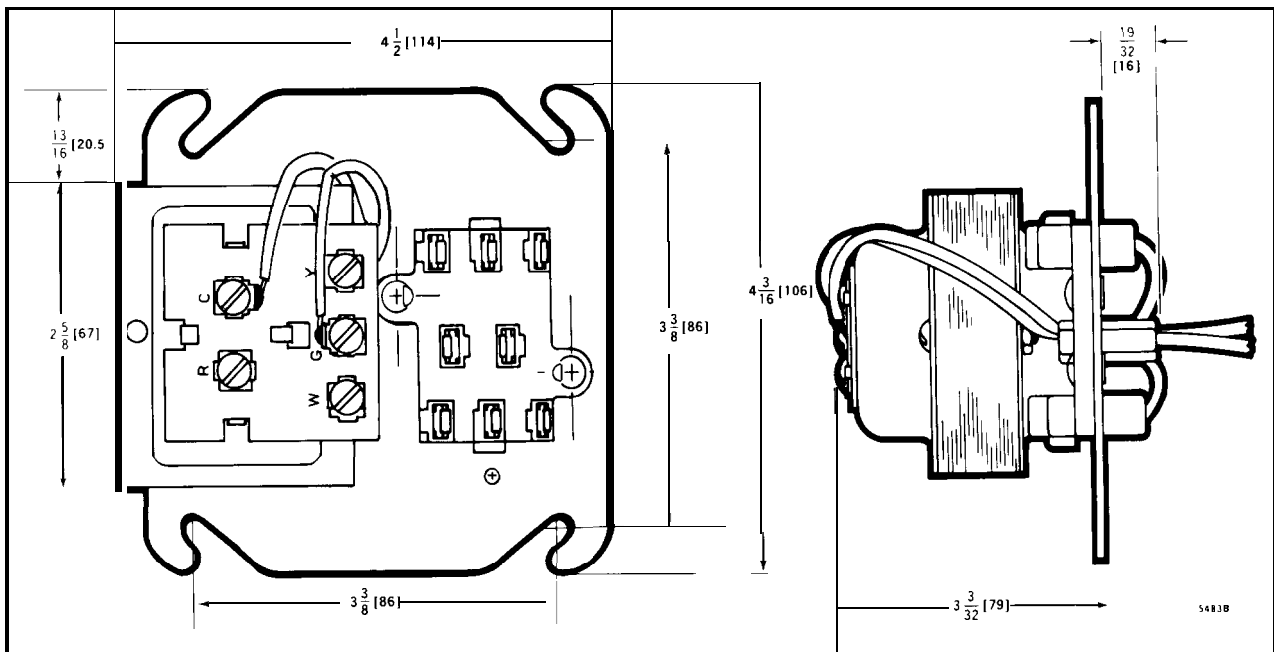

FIG. 3-APPROXIMATE AT72H,J INSTALLATION DIMENSIONS IN INCHES [MILLIMETRES].

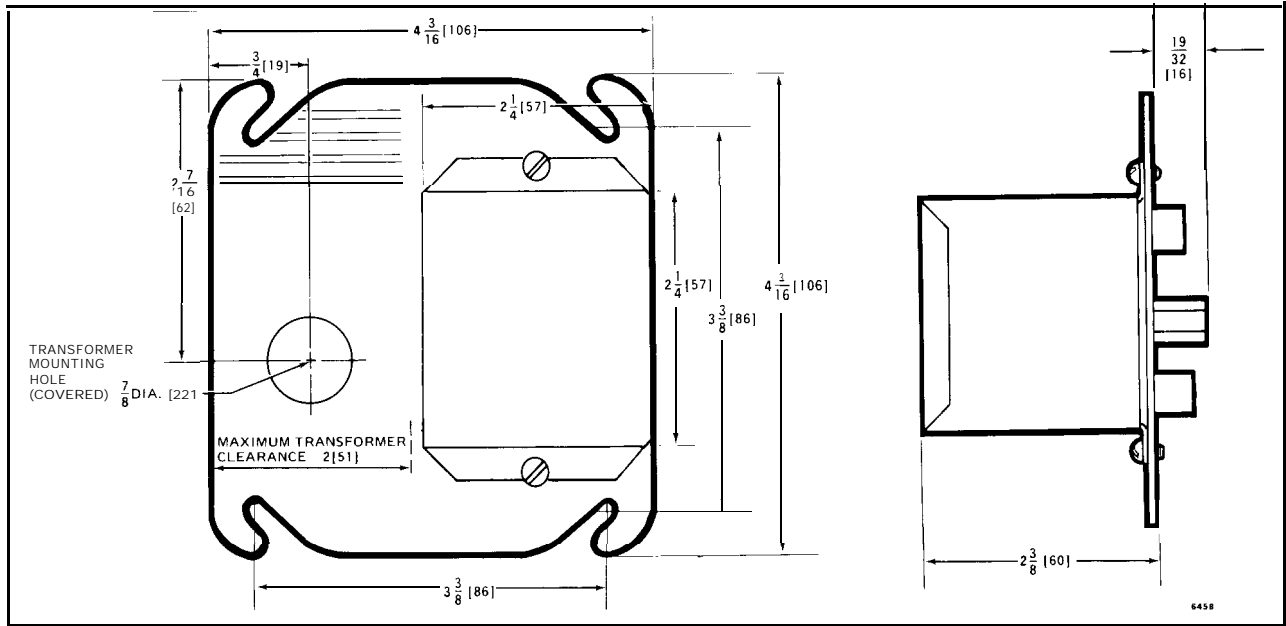

FIG. 4—APPROXIMATE Q633A1003 INSTALLATION DIMENSIONS IN INCHES [MILLIMETRES].

MEETS NEMA ST2-1973 “RESIDENTIAL CONTROLS-CLASS 2 TRANSFORMER,” classification marked “NEMA Type D.”

ACCESSORIES:

The R8239 function can be achieved by plugging

an appropriate R8222 or R8228 relay into an AT72H,J transformer. The wiring hookups are similar to Figs. 5-9 with the exception of some leadwire colors. Order the appropriate relay, using Table I. The metal cover, Part No. 138705, is available to enclose the relay.

INSTALLATION

CAUTION

1. Disconnect power supply to prevent electrical shock and equipment damage.
2. Installer must be a trained, experienced service technician.
3. Always conduct a thorough checkout when installation is complete.

MOUNTING

The R8239, AT72H,J and Q633A1007 mount on a standard 4 inch square junction box. Make wiring connections in the junction box; then fasten the fan center to the box, placing the junction box screws through notches in the fan center mounting plate.

On receptacles without relays, select and mount the appropriate relay (Table I) and attach the relay cover. A label identifying the relay used (furnished with TRADE LINE models) should be applied to the relay cover.

NOTE: Relay may be mounted in any position. With the terminals pointing down, pickup voltage is increased by 12 percent.

WIRING

All wiring must comply with local codes and ordinances. Refer to information furnished with the system equipment or refer to Figs. 5-8 showing internal schematics and typical hookups for the fan centers. For R8239F, see Fig. 8; for Q633A1007, see Fig. 10.

IMPORTANT

When making external connections to the line voltage leadwires of this device, use only Underwriters Laboratories Inc. listed connectors.

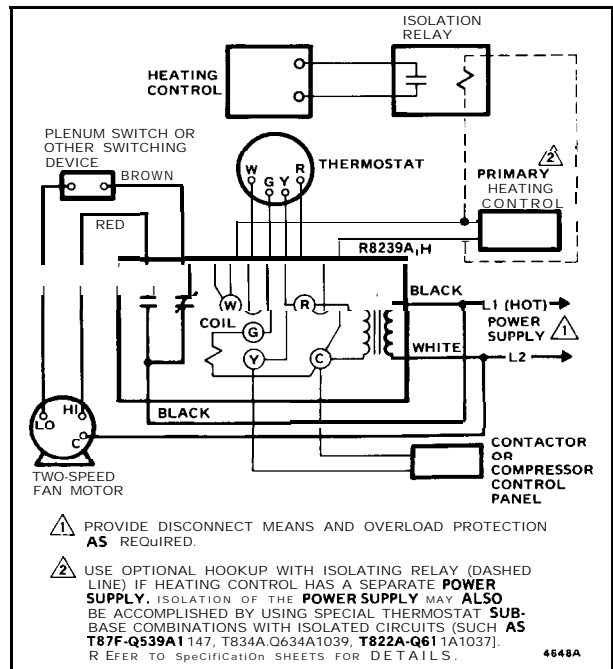

FIG. 5—R8239A,H TYPICAL HOOKUP WITH 2-SPEED FAN IN HEATING-COOLING SYSTEM.