

## FACTORY JACKETED AND INSULATED STORAGE TANKS

These A. O. Smith storage tanks are designed for storing potable water. Fitting locations are designed to meet the needs of normal installations plus those for the A. O. Smith Cer-Temp 80® and Shure-Temp™ piping methods.

### FEATURES

A. O. Smith storage tanks are ideal for use with gas-fired copper heat exchanger equipment for storage of any potable water at temperatures up to 180°F.

**GLASSLINED TANK** - Alkaline borosilicate composition permanently fused to steel by firing at a temperature of 1600°F, providing years of corrosion protection and dependable use.

**HEAVY GAUGE STEEL JACKET** - With baked enamel finish.

**THREADED OPENINGS** - All tanks furnished with threaded openings for thermometer, relief valve, 2" recirculation lines, tankstat, and drain valve.

**INSULATION** - Storage Tanks meet or exceed R12.5 minimum thermal insulation requirements of the U. S. Department of Energy and current edition of ASHRAE/IESNA 90.1

**TJ-80S, TJ-80A, TJV-120M and TJV-120A**

- Fits through 30" door
- Magnesium anode for anti-corrosion protection

#### TJ-80A

- 80 gallons
- High density foam insulation saves energy, helps reduce standby heat loss
- 160 psi ASME standard working pressure

#### TJV-120A

- 119 gallons
- High density foam insulation saves energy, helps reduce standby heat loss
- 160 psi ASME standard working pressure

#### TJ-80S

- 80 gallons
- High density foam insulation saves energy, helps reduce standby heat loss
- 160 psi working pressure

#### TJV-120M

- 119 gallons
- High density foam insulation saves energy, helps reduce standby heat loss
- 160 psi working pressure

### OPTIONS

Perfectly balanced manifold kits (120 gallon models) allow installation where 240 to 480 gallons of stored water is required.

#### TJV-200-M - 175 GALLONS

- 160 psi ASME standard working pressure
- 2" foam insulation
- Handhole cleanout (Standard)
- Fits through 33" door
- Storage is downsized to 175 gallons for a 32" x 77" envelope for space restrictive installations. Model TJV-200 is available with 200 gallons of storage.
- Magnesium anodes for extra corrosion protection

### 5 YEAR WARRANTY

If the tank should leak any time during the first 5 years, under the terms of the warranty, A. O. Smith will repair or replace the tank. Installation, labor, handling and local delivery are extra. For complete information, consult the written warranty.

## MODELS TJ-80S, TJ-80A TJV-120A, TJV-120M & TJV-200M



120 Gallon Model



**ASME**  
(FOR SELECT MODELS)

### TJV-120M

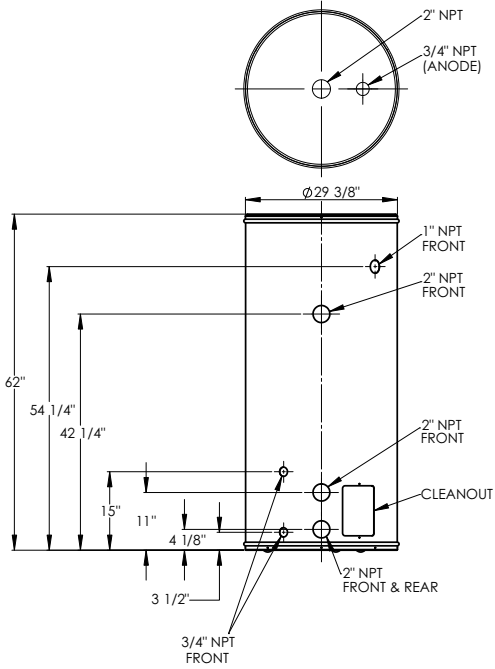

### TJV-120A

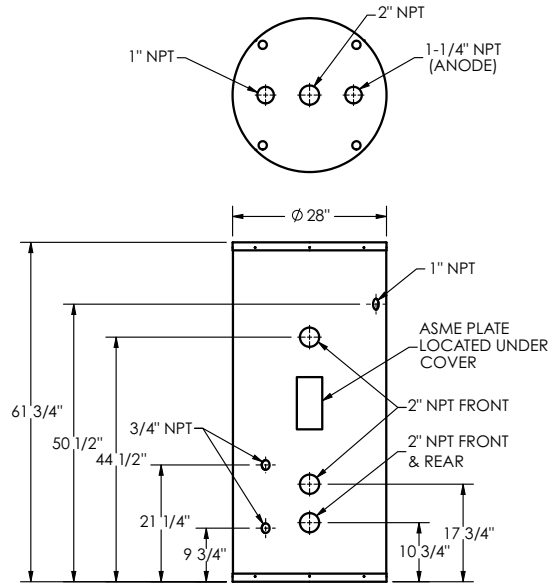

### TJV-200M

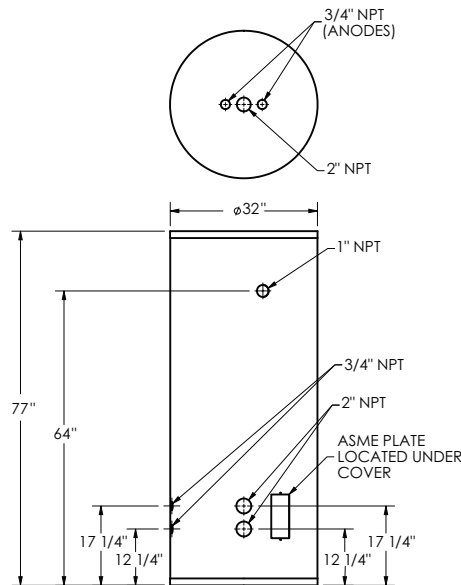

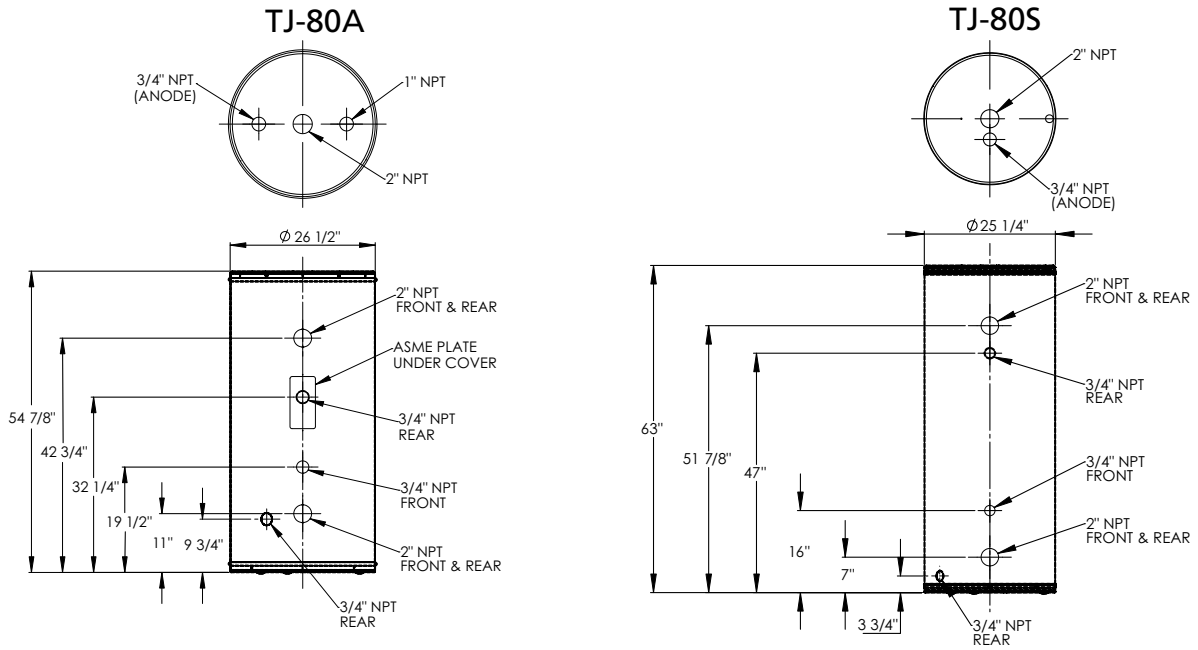

## FLOOR SPACE REQUIREMENTS

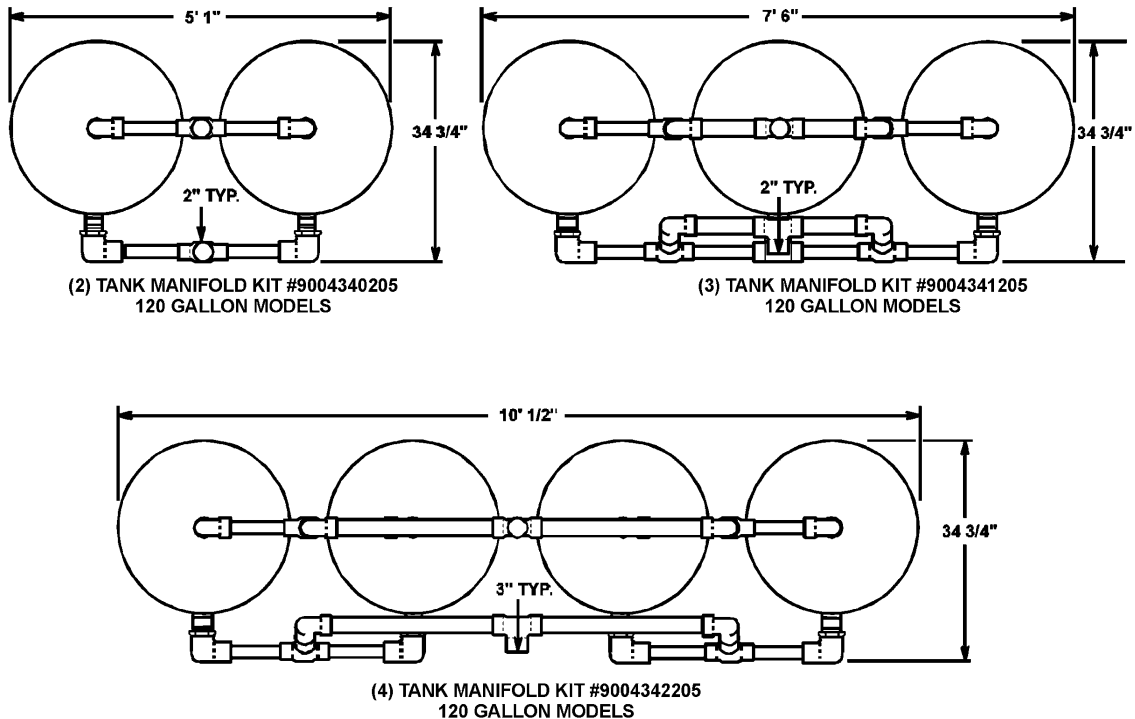



# Commercial Storage Tanks

## **SUGGESTED SPECIFICATION**

Storage tank shall be A.O. SMITH glasslined storage tank. Tank shall be \_\_\_\_\_ " x \_\_\_\_\_ " and have a nominal capacity of \_\_\_\_\_ gallons. Tank(s) shall have threaded openings as shown on drawings. Interior of tank(s) shall be glasslined with an alkaline borosilicate composition which has been fused to the steel by firing at a temperature of 1600°F. Glass coating shall be continuous over the entire inner surface of the tank. Outer jacket shall have a baked enamel finish. Meets minimum thermal insulation requirements of the U.S. Department of Energy and current edition of ASHRAE/IESNA 90.1. Cathodic protection shall be provided. Tank shall have a working pressure of \_\_\_\_\_ psi. Tank shall have a five year limited warranty as outlined in the written warranty.