

INSTRUCTIONS FOR REMOVING & REPLACING THE MANIFOLD/BURNER ASSEMBLY

Kit Contents: Manifold/Burner Assembly, Ferrule nut & screws.

Important: For correct water heater operation, it is essential that the manifold/burner assembly be properly installed. If you lack the necessary skills to properly perform the installation, you should not proceed, but get help from a qualified person.

Removing the Manifold/Burner Assembly

1. Turn the gas control/temperature knob to the "OFF" position (Figure 2).
2. Before performing any maintenance, it is important to turn off the gas supply to the water heater at the manual gas shut-off valve. This valve is typically located beside the water heater. Note the position of the shut-off valve in the open/on position then proceed to turn it off (Figure 1).
3. With the unit shut-off allow sufficient time for the water heater to cool before performing any maintenance.
4. Remove the outer door (Figure 1).
5. Disconnect the pilot tube (7/16" wrench), the igniter wire from the igniter lead wire, and manifold tube (3/4" wrench) at the gas control valve/thermostat (Figure 2).
NOTE: L.P. Gas systems use reverse (left-hand) threads on the manifold tube.
6. Disconnect the white and red wires from the gas control valve/thermostat (Figure 2). Use needle nose pliers to grip the connector(s).

IMPORTANT: Grip the connector carefully to prevent damage. Do not grip or pull the wires themselves.

7. Grasp the manifold tube and push down slightly to free the manifold tube and pilot tube.
8. Remove the screws (1/4" nut driver) securing the manifold/burner assembly to the combustion chamber (Figure 5). Carefully remove the manifold/burner assembly from the combustion chamber. **BE SURE NOT TO DAMAGE ANY INTERNAL PARTS.**

Replacing the Manifold/Burner Assembly

IMPORTANT: DO NOT operate the water heater without the orifice installed. See Figures 3 and 4.

1. Check the new manifold/burner assembly's door gasket for damage or embedded debris prior to installation. Replace if damaged.
2. Inspect the viewport for damage and replace as required. See Figure 5.
3. Insert the new manifold/burner assembly into the combustion chamber, making sure that the tab of the manifold tube engages in the slot of the bracket inside the combustion chamber. (See Figures 3 and 4, referring to the graphic that applies to your model).
4. Inspect the door gasket and make sure there is no fiberglass insulation between the gasket and the combustion chamber.
5. Tighten the two screws which secure the manifold/burner assembly to the combustion chamber. There should be no space between the gasket part of the manifold door and the combustion chamber.

IMPORTANT: Do not operate the water heater if the door gasket does not create a seal between the manifold door and the combustion chamber.

WARNING

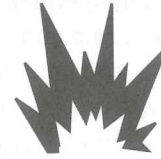

Explosion Hazard

- Tighten both manifold door screws securely.
- Remove any fiberglass between gasket and combustion chamber.
- Replace viewport if glass is missing or damaged.
- Replace manifold component block if missing or removed.
- Replace door gasket if damaged.
- Failure to follow these instructions can result in death, explosion, or fire.

Figure 1
Gas Piping

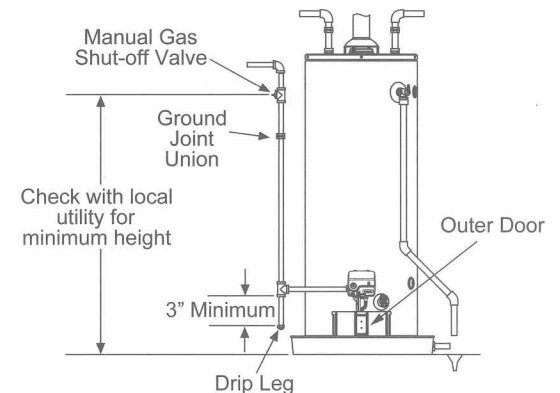
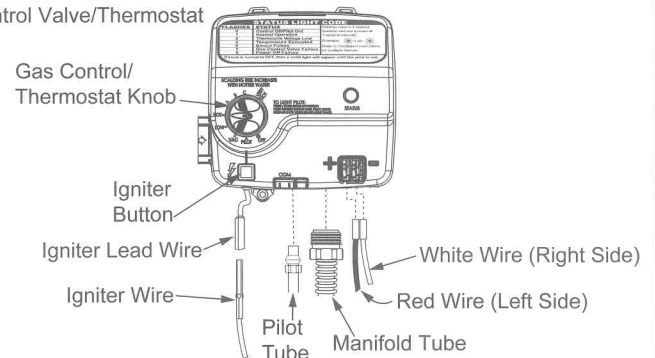

Figure 2
Gas Control Valve/Thermostat



6. Reconnect the manifold tubing (3/4" wrench) to the gas control valve/thermostat. See Figure 2. NOTE: L.P. Gas systems use reverse (left-hand) threads on the manifold tube. Do not cross-thread. Do not apply any thread sealant to these fittings. Install ferrule nut supplied with kit into the gas valve at the pilot tube location, hand tight only. Insert pilot tube into ferrule nut until tube bottoms out then tighten nut with a 7/16" wrench until crimp connection seals to pilot tube. Continue to tighten until the nut is tight in gas valve.
7. Connect the white and red wires to the gas control valve/thermostat as shown in Figure 2. Also, ensure that the red thermal switch wires are connected to the thermal switch on the manifold door (Figure 5).
8. Reconnect the igniter wire (Figure 2).
9. Turn on the gas supply to the water heater at the manual gas shut-off valve (Figure 1).
10. Follow the lighting instructions on the front of the water heater. With the main burner lit, check for leaks at the manifold and pilot connections by brushing on an approved noncorrosive leak detection solution, or a mixture of hand dish washing soap and water (one part soap to 15 parts water) or children's soap bubble solution. Bubbles forming indicate a leak. Correct any leak found. Verify proper operation and then replace the outer door.

