

INSTALLATION INSTRUCTIONS FOR REPLACING THE MANIFOLD/BURNER ASSEMBLY

IMPORTANT: For correct water heater operation, it is essential that the Manifold/Burner Assembly be properly installed. If you lack the necessary skills to properly perform the installation, you should not proceed, but get help from a qualified technician.
NOTE: L.P. gas systems use left-handed threads on the manifold tube. However, mobile home units are an exception. Mobile home units use right-handed threads on the manifold tube for both L.P. and natural gas systems.

Removing the Manifold/Burner Assembly

1. Turn off the gas supply to the water heater at the manual gas shut-off valve. This valve is typically located beside the water heater. Note the position of the shut-off valve in the open/on position then proceed to turn it off (Figure 1).
2. On the lower front of the water heater locate the gas control valve/thermostat (see Figure 1). Before performing any maintenance, it is important to turn the temperature dial on the gas control valve/thermostat to its lowest setting.
3. On top of the gas control valve/thermostat, turn the gas control knob to the "OFF" position. **NOTE:** On the White Rodgers gas control valve/thermostat, the knob must first be slightly depressed before turning the gas control knob. On the Robertshaw gas control valve/thermostat, the dial stop must first be depressed before turning the gas control knob. See the Lighting Instructions on the water heater.
4. Remove the outer door.
5. Disconnect the thermocouple (right-hand thread), pilot tube, the igniter wire from the igniter button, the two wire leads attached to the thermal switch, and manifold tube at the gas control valve/thermostat. (Figures 2.)
6. Remove the two screws securing the manifold door assembly to the combustion chamber (Figure 1).
7. Grasp the manifold tube and push down slightly to free the manifold, pilot tube, and thermocouple.
8. Carefully remove the manifold/burner assembly from the burner compartment. **NOTE:** Be sure not to damage internal parts.

Replacing the Manifold/Burner Assembly

1. Check the door gasket for damage or imbedded debris prior to installation.
2. Inspect the view port for damage and replace as required.
3. Insert the manifold/burner assembly into the burner compartment making sure that the tip of the manifold tube engages in the slot of the bracket inside the combustion chamber (Figure 3).
4. Inspect the door gasket and make sure there is no fiberglass insulation between the gasket and the combustion chamber.
5. Replace the two screws, which secure the manifold/burner assembly door to the combustion chamber and tighten securely. Once the manifold/burner assembly door is tightened, visually inspect the door gasket between the manifold/burner assembly door and the combustion chamber for spaces or gaps that would prevent a seal. **IMPORTANT:** DO NOT operate the water heater if the door gasket does not create a seal between the manifold door and the combustion chamber.
6. During the following procedure, do not cross-thread or apply any thread sealant to any of the fittings listed below. First, reconnect the manifold tubing to the gas control valve/thermostat. Second, install the provided ferrule nut in the gas control valve/thermostat at the pilot location, hand tight only. Next, insert the pilot tube into the ferrule nut until it bottoms out. **NOTE:** Hold the tube in this position. Tighten the ferrule nut with a wrench until the crimp connection seals to the pilot tube. Continue to tighten until the nut is tight in the gas control valve/thermostat. Finally start the thermocouple nut and turn it all the way in by hand. An additional quarter turn with a 3/8" open-end wrench will then be sufficient to seat the lockwasher. When you are finished, connect the igniter wire to the piezo igniter. (If this

WARNING



Explosion Hazard

- Tighten both manifold door screws securely.
- Remove any fiberglass between gasket and combustion chamber.
- Replace viewport if glass is missing or damaged.
- Replace manifold component block if missing or removed.
- Replace door gasket if damaged.
- Failure to follow these instructions can result in death, explosion, or fire.

FIGURE 1
MANIFOLD/BURNER ASSEMBLY
REMOVAL

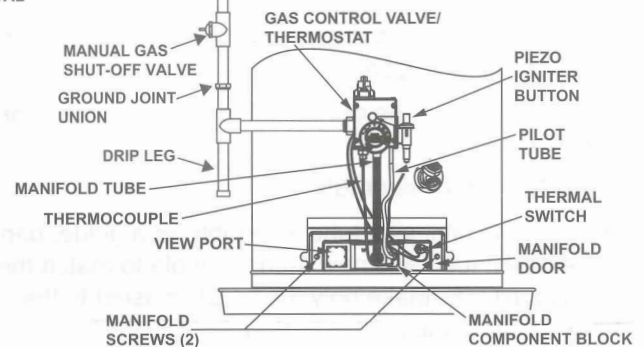

FIGURE 2
GAS CONTROL VALVE/THERMOSTAT

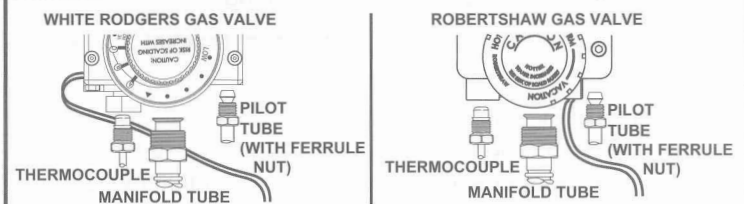
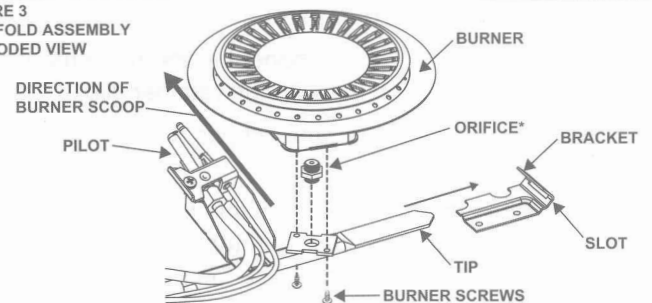

FIGURE 3
MANIFOLD ASSEMBLY
EXPLODED VIEW



*NOTE: L.P. GAS SYSTEMS USE REVERSE (LEFT-HAND) THREADS ON THE ORIFICE.

7. leaves the wire connector exposed, unplug the igniter wire and slide the insulating sleeve onto the wire. Reconnect the igniter wire to the piezo igniter, then slide the insulating sleeve over the exposed wire connector. If necessary, tape to hold in place.)
8. Reconnect the two wire leads that go to the thermal switch.
9. Turn gas supply on and refer to the Lighting Instructions.
10. With the burner lit, check the gas control valve/thermostat supply line, manifold tube, and pilot tube connections for leaks. Check for leaks by brushing on an approved noncorrosive leak detection solution. Bubbles forming indicate a leak. Correct any leak found. **IMPORTANT:** All leaks must be fixed immediately.
10. Replace the outer door.

INSTRUCTIONS FOR REPLACING PILOT ASSEMBLY

Kit Contents: 1 Pilot Assembly, 1 Ferrule Nut, 1 Insulating Sleeve

IMPORTANT: For correct water heater operation, it is essential that the pilot assembly be properly installed. If you lack the necessary skills to properly perform the installation, you should not proceed, but get help from a qualified technician.

Removing the Pilot Assembly

1. Follow the "Removing the Manifold/Burner Assembly" instructions on the opposite side of this sheet to remove the manifold/burner assembly.
2. Take off the burner by removing the two (2) screws located underneath the burner (Figure 1). **NOTE:** Do not remove the burner orifice.
3. Lift the retainer clip straight up from the back of the manifold component block (using a flat-blade screwdriver), then remove the manifold component block from the manifold door (Figure 2). **IMPORTANT:** Be careful not to bend or alter the position of the pilot tube. It will be used as a bending template for the new pilot assembly.
4. Remove and keep the screw securing the pilot assembly to the pilot bracket (Figure 3).
5. Remove and keep the old pilot/pilot tube assembly for reference.

Replacing the Pilot Assembly

1. Using the old pilot/pilot tube assembly as a guide, bend the new pilot tube and new thermocouple to match the old ones. **NOTE:** Make only the bends closest to the pilot before going to the next step (Figure 3).
2. Route the new pilot tube, thermocouple, and igniter wire through the manifold/burner door opening.
3. Re-attach the pilot assembly to the pilot bracket and secure using the screw removed earlier (Figure 3).
4. Position the new pilot tube through the largest opening of the manifold component block. **NOTE:** The largest opening should be located at the top position. The igniter wire should be located in the middle opening and thermocouple in the bottom opening (Figure 4).
5. Reposition the manifold component block in the manifold door opening and secure it with the retainer clip.
6. Re-attach the burner using the screws removed earlier (Figure 1).
7. Carefully bend the new pilot tube and thermocouple to match the bend of the manifold tube. **NOTE:** When bending, **DO NOT** crimp or crease the pilot tube or thermocouple.
8. Follow the "Replacing the Manifold/Burner Assembly" instructions on the opposite side of this sheet to replace the manifold/burner assembly.

