

AIR FILTER ACCESSORY INSTALLATION INSTRUCTIONS

Kit Contents: "Air Filter Assembly, with Instruction".

IMPORTANT: Failure to install properly (and clean) the Air Filter Assembly can allow dust and lint to restrict the air supply to the water heater. If that occurs, the pilot light could go out or the thermal switch could shut the water heater off. A service call could be needed to clean the flame trap/arrestor. These conditions are not defects and are not covered by the warranty.

Install the Air Filter Assembly as described below and clean as needed. Replace the Air Filter Assembly with a new one if it is damaged.

Filter Installation:

1. Before installing the Air Filter Assembly, remove any dust, lint or debris (including any packaging materials or tape) from under the water heater.
2. **Installation:** Wrap the filter around the base of the water heater. Cut to fit around a sensor if present. Trim excess filter material with scissors but allow filter material to overlap a few inches (see Figure 2).
3. The filter should fit snugly against base of water heater with no gaps. The filter must fit flush against the bottom of the drain pan *and/or* floor. Hold the filter in place, stretch the filter clip over the overlapped joint and hook in place (see Figure 2).
4. Check the filter at least every three months and clean as necessary. After installation, the filter may be cleaned by using a vacuum cleaner with a brush attachment to remove lint and dust. **NOTE:** because the amount of dust and lint in the air can vary, your filter may need to be inspected/cleaned more often. In some instances, the filter may need to be removed and washed using mild hand soap and water to remove any oily residue. After washing allow to dry and properly reinstall.

NEVER OPERATE THE WATER HEATER WITHOUT A CLEAN AIR FILTER.

**FIGURE 1
KIT CONTENTS:**

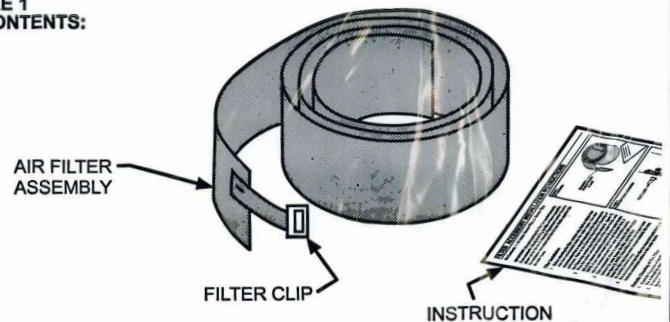

**FIGURE 2
AIR FILTER ASSEMBLY INSTALLATION:**

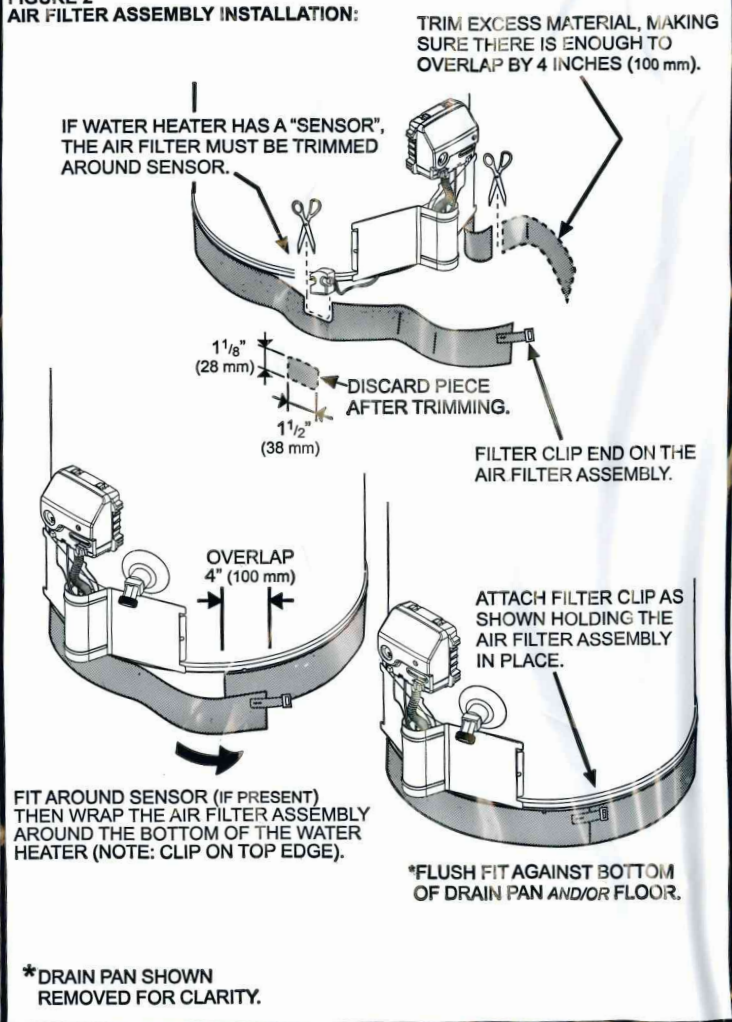



INSTALLATION INSTRUCTIONS FOR REPAIR PARTS

WARNING!

This repair kit shall be installed by a qualified service agency in accordance with the manufacturer's instructions and all applicable codes and requirements of the authority having jurisdiction. The information in these instructions must be followed to minimize the risk of fire or explosion or to prevent property damage, personal injury or death. The qualified service agency is responsible for the proper installation of this kit. The installation is not proper and complete until the operation of the appliance is checked as specified in the manufacturer's instructions.

INTRODUCTION

These instructions are intended for the installation of parts for units with Flammable Vapor Ignition Resistant Technology (FVIR). The end result of using these instructions and this kit is to effect proper repairs of these flammable vapor ignition resistant water heaters.

Please make sure you have the correct kit number for the model water heater you have before starting the installation.

IMPORTANT

The installation of this kit requires ability equivalent to that of a licensed tradesman in the field involved. Air supply, venting and gas supply are required. These instructions as well as the manual that came with the water heater must be read thoroughly and understood before attempting any of the repairs covered herein.

All WARNINGS and CAUTIONS in both these instructions and the manual that came with the water heater must be carefully observed at all times.

WARNING!

Improper installation could result in a hazardous condition such as explosion or carbon monoxide poisoning resulting in serious personal injury or death.

PREPARATION

Before beginning repairs do the following:

1. Shut off the gas supply to the water heater.
2. Rotate the thermostat dial on the water heater control counter-clockwise until the main burner ignites and burns off all residual gas in the control and supply lines.
3. Rotate the thermostat dial clockwise back to the "PILOT LIGHTING" position.

Tools Required:

3/8", 7/16", and 3/4" Open-end wrenches
3/8" Nut driver
Phillips-head screwdriver

A. Removing Old Burner Assembly:

1. Remove outer door.
2. Remove nuts holding inner door in place with 3/8" nut driver.
3. Unplug wire from igniter assembly mounted on the top of the gas valve.
4. Loosen flare nut holding thermocouple to bottom of gas valve with 3/8" open-end wrench and pull down to remove.
5. Loosen flare nut holding pilot line to bottom of gas valve with 7/16" open-end wrench and pull tube down to remove.
6. Loosen flange nut holding burner tube to bottom of gas valve with 3/4" open-end wrench and pull down to remove.
7. Grasp burner tube and remove burner assembly through inner door opening, see Figure 1.

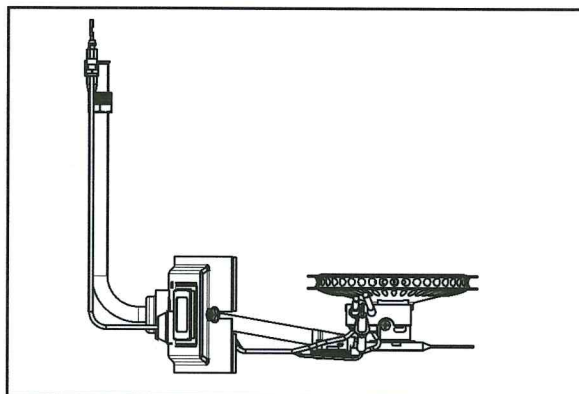

Figure 1. BURNER ASSEMBLY

B. Installing New Burner Assembly:

1. Insert new burner assembly through the door opening being careful not to damage the door gasket on the studs, see Figure 1. The burner tube must rest in the support bracket inside the combustion chamber, see Figure 2. Be sure the igniter wire and pilot tubing do not bow up where the flame may damage them. The inner door should fit with the studs extending through the slots in the door. Check to see if the door gasket extends uniformly around the door, see Figure 3. This will ensure that the gasket is not folded and properly seals the combustion chamber.

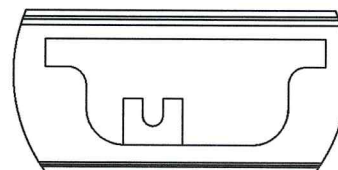

Figure 2. BURNER SUPPORT

2. Put the burner tube into the bottom of the gas valve and tighten the flare nut. Ensure that the burner tube remains in the support bracket inside the combustion chamber.
3. Insert the pilot tube into the bottom of the gas valve and tighten the flare nut.

Figure 3. INNER DOOR GASKET

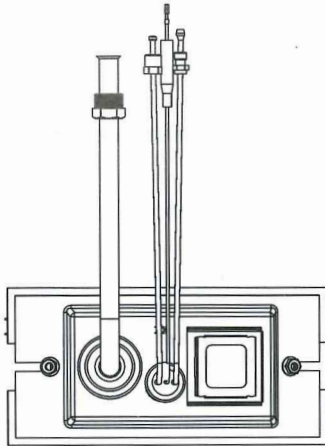

Figure 4. BURNER ASSEMBLY PARTS

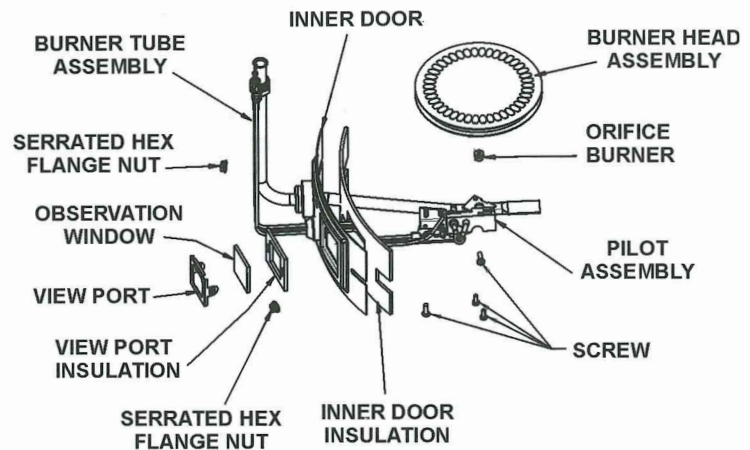

Figure 5. BURNER HEAD & TCO SCREWS

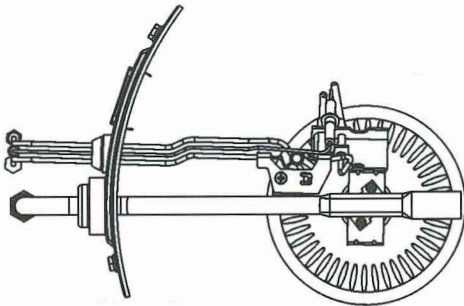
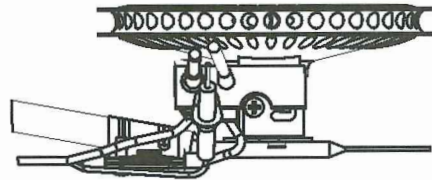

Figure 6. PILOT ASSEMBLY & TCO



4. Insert the thermocouple into the bottom of the gas valve and tighten the flare nut.
5. Plug wire from combustion chamber into igniter assembly located on the top of the gas valve. Wire should be routed behind burner tube and gas supply line.
6. Install serrated flange nuts on studs and tighten to hold inner door in place.
7. Make sure burner tube boot is on flange on inner door and pilot assembly grommet is secure in the hole in the inner door.
8. Light pilot following the lighting and operating instructions on the front surface of the heater.
9. Install outer door.

C. Replacing Burner Head: (See Figure 4)

1. Follow steps 1 to 7 in A above to remove burner assembly,
2. Remove the Phillips-head screw holding the TCO bracket to the burner tube bracket, see Figure 5.
3. Remove the Phillips-head screw holding the pilot bracket to the burner head, see Figure 6.
4. Remove the two Phillips-head screws holding the burner head to the burner tube assembly, see Figure 5
5. Pull the burner tube boot off the flange on the inner door and remove the burner tube assembly.
6. Push the pilot assembly grommet out of the inner door towards the combustion chamber.
7. Pull the igniter wire, thermocouple, and pilot tube through the inner door hole.

8. Remove the gasket from the inner door and replace it with a new gasket.
9. Feed the igniter wire, thermocouple, and pilot tube through the inner door hole.
10. Push the grommet into the inner door hole making sure the door fits into the groove in the grommet.
11. Insert the burner tube assembly through the inner door and place the boot on the inner door flange.
12. Fasten the new burner head to the burner tube assembly using two Phillips-head screws, see Figure 5.
13. Fasten the pilot bracket to the new burner head with a Phillips-head screw, see Figure 5.
14. Fasten the TCO bracket to the burner tube bracket with a Phillips-head screw, see Figure 5.
15. Follow steps 1 to 9 in B above to install the burner assembly.

D. Replacing Burner Orifice: (See Figure 4)

1. Follow steps 1 to 7 in A above to remove burner assembly,
2. Remove the Phillips-head screw holding the TCO bracket to the burner tube, see Figure 5.
3. Remove the two Phillips-head screws holding the burner head and pilot assembly to the burner tube assembly, see Figure 5.
4. Pull the burner tube boot off the flange on the inner door and remove the burner tube assembly.
5. Remove the orifice from the burner tube and replace it with the new one using a 3/8" open-end wrench, see Figure 4.

6. Push the pilot assembly grommet out of the inner door towards the combustion chamber, see Figure 3.
7. Pull the igniter wire, thermocouple, and pilot tube through the inner door hole.
8. Remove the gasket from the inner door and replace it with a new gasket, see Figure 3.
9. Feed the igniter wire, thermocouple, and pilot tube through the inner door hole.
10. Push the grommet into the inner door hole making sure the door fits into the groove in the grommet.
11. Insert the burner tube assembly through the inner door and place the boot on the inner door flange.
12. Align the burner head mounting bracket holes with the holes in the burner tube bracket and fasten with two Phillips-head screws, see Figure 5.
13. Fasten the TCO bracket to the burner tube bracket with a Phillips-head screw, see Figure 5.
14. Follow steps 1 to 9 in B above to install the burner assembly.

E. Replacing Burner Tube Assembly: (See Figure 4)

1. Follow steps 1 to 7 in B above to remove burner assembly.
2. Remove the Phillips-head screw holding the TCO bracket to the burner tube, see Figure 5.
3. Remove the two Phillips-head screws holding the burner head and pilot assembly to the burner tube assembly, see Figure 5.
4. Pull the burner tube boot off the flange on the inner door and remove the burner tube assembly.
5. Remove the orifice from the burner tube assembly with a 3/8" open-end wrench, see Figure 4.
6. Push the pilot assembly grommet out of the inner door towards the combustion chamber.
7. Pull the igniter wire, thermocouple, and pilot tube through the inner door hole.
8. Remove the gasket from the inner door and replace it with a new gasket, see Figure 3.
9. Feed the igniter wire, thermocouple, and pilot tube through the inner door hole.
10. Push the grommet into the inner door hole making sure the door fits into the groove in the grommet.
11. Install the orifice in the new burner tube assembly with a 3/8" open-end wrench, see Figure 4.
12. Insert the new burner tube assembly through the inner door and place the boot on the inner door flange.
13. Align the burner head mounting bracket holes with the holes in the burner tube bracket and fasten with two Phillips-head screws, see Figure 5.
14. Fasten the TCO bracket to the burner tube bracket with a Phillips-head screw, see Figure 5.
15. Follow steps 1 to 9 in B above to install the burner assembly.

F. Replacing Pilot Assembly: (See Figures 3 through 6)

1. Follow steps 1 to 7 in A above to remove burner assembly.
2. Remove the Phillips-head screw holding the TCO bracket to the burner tube, see Figure 5.
3. Remove the Phillips-head screw holding the pilot bracket to the burner head, see Figure 6.
4. Push the pilot assembly grommet out of the inner door towards the combustion chamber.
5. Pull the igniter wire, thermocouple, and pilot tube through the inner door hole.
6. Remove the two Phillips-head screws holding the burner head and pilot assembly to the burner tube assembly, see Figure 5.
7. Pull the burner tube boot off the flange on the inner door and remove the burner tube assembly.
8. Remove the gasket from the inner door and replace it with a new gasket, see Figure 3.
9. Feed the new igniter wire, thermocouple, and pilot tube through the inner door hole.

10. Position grommet on the pilot assembly so that excess tubing/wiring is located on the outer side of the inner door. Note: that replacement pilot assemblies may be longer than factory installed parts.
11. Push the grommet into the inner door hole making sure the door fits into the groove in the grommet.
12. Insert the burner tube assembly through the inner door and place the boot on the inner door flange.
13. Fasten the pilot bracket to the burner head with a Phillips-head screw, see Figure 5.
14. Fasten the TCO bracket to the burner tube bracket with a Phillips-head screw, see Figure 5.
15. Align the burner head mounting bracket holes with the holes in the burner tube bracket and fasten with two Phillips-head screws, see Figure 5.
16. Follow steps 1 to 9 in B above to install the burner assembly.

G. Replacing Inner Door: (See Figure 4)

1. Follow steps 1 to 7 in A above to remove burner assembly.
2. Remove the Phillips-head screw holding the TCO bracket to the burner tube, see Figure 5.
3. Remove the two Phillips-head screws holding the burner head and pilot assembly to the burner tube assembly, see Figure 5.
4. Push the pilot assembly grommet out of the inner door towards the combustion chamber.
5. Pull the igniter wire, thermocouple, and pilot tube through the inner door hole.
6. Pull the burner tube boot off the flange on the inner door and remove the burner tube assembly.
7. Place the new gasket on the new inner door, see Figure 3.
8. Feed the igniter wire, thermocouple, and pilot tube through the inner door hole.
9. Push the grommet into the inner door hole making sure the door fits into the groove in the grommet.
10. Insert the burner tube assembly through the inner door and place the boot on the inner door flange.
11. Align the burner head mounting bracket holes with the holes in the burner tube bracket and fasten with two Phillips-head screws, see Figure 5.
12. Fasten the TCO bracket to the burner tube bracket with a Phillips-head screw, see Figure 5.
13. Follow steps 1 to 9 in B above to install the burner assembly.

H. Replacing Inner Door Gasket: (See Figure 4)

1. Follow steps 1 to 7 in A above to remove burner assembly.
2. Remove the Phillips-head screw holding the TCO bracket to the burner tube, see Figure 5.
3. Remove the two Phillips-head screws holding the burner head and pilot assembly to the burner tube assembly, see Figure 5.
4. Push the pilot assembly grommet out of the inner door towards the combustion chamber.
5. Pull the igniter wire, thermocouple, and pilot tube through the inner door hole.
6. Pull the burner tube boot off the flange on the inner door and remove the burner tube assembly.
7. Remove the gasket from the inner door and replace it with the new gasket, see Figure 3.
8. Feed the igniter wire, thermocouple, and pilot tube through the inner door hole.
9. Push the grommet into the inner door hole making sure the door fits into the groove in the grommet.
10. Insert the burner tube assembly through the inner door and place the boot on the inner door flange.
11. Align the burner head mounting bracket holes with the holes in the burner tube bracket and fasten with two Phillips-head screws, see Figure 5.
12. Fasten the TCO bracket to the burner tube bracket with a Phillips-head screw, see Figure 5.
13. Follow steps 1 to 9 in B above to install the burner assembly.

FVIR C3 WATER HEATER FLAME ARRESTOR CLEANING INSTRUCTIONS

INCLUDED IN THIS KIT:

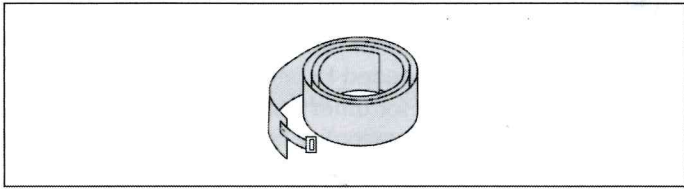

- Wrap-around style filter (with clip)

To perform the cleaning instructions below, the following tools/household items are needed:

- Vacuum cleaner with hose attachment (crevice tool)

CLEANING THE FLAME ARRESTOR:

1. Turn the water heater gas control knob to "off" (See Figure 1) and allow the water heater to cool for about 15 minutes. Remove the outer door.

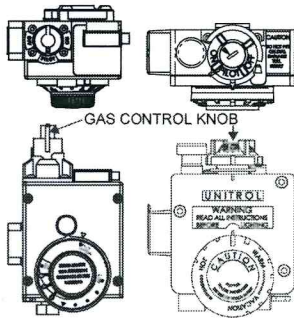

Figure 1

2. If your installation has the snap-in style filter shown in Figure 2, remove and set it aside.

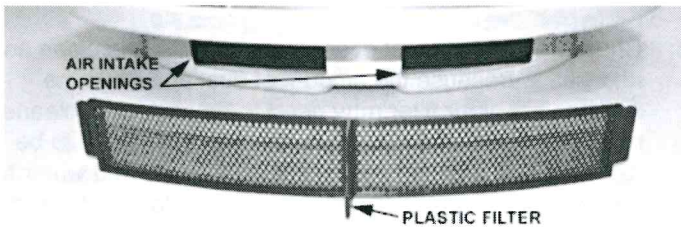

Figure 2

3. Insert the flexible cleaning brush into the air intake openings (See Figure 3).



Figure 3

Use an in and out motion to remove dust/debris from the flame arrestor. Periodically pull the brush from the water heater and use the vacuum to remove any dust/debris from the brush. Repeat this procedure until the flexible cleaning brush does not retrieve any further dust/debris (See Figure 4).

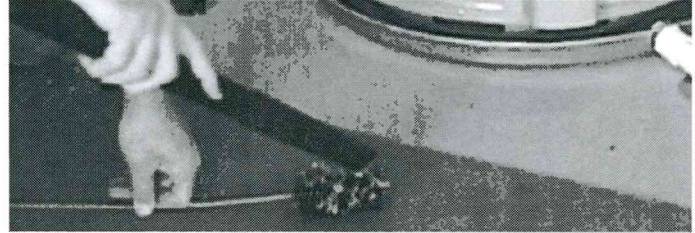

Figure 4

4. Once the flame arrestor is free from dust/debris, use the vacuum crevice tool to remove any dust/debris inside the base of the water heater. Also clean the area adjacent to the water heater, including the drain pan (if one is installed).



Figure 5

INSTALLING THE WRAP-AROUND STYLE FILTER:

NOTE: Do not use this wrap-around style filter if your water heater is installed on a pedestal or stand that does not have a solid level base or drain pan. In that case clean and reuse the original snap-in style filter.

IMPORTANT: For proper operation the water heater **MUST** have a filter installed, either the original snap-in style filter or a properly fitted wrap-around style filter but not both.

1. Before installing the wrap-around style filter, remove any dust, lint or debris (including any packaging materials or tape) from under the water heater.
2. **Installation:** Wrap the filter around the base of the water heater. Cut to fit around a sensor if present. Trim excess filter material with scissors but allow filter material to overlap a few inches (see Figure 6).

- The filter should fit snugly against base of water heater with no gaps. The filter must fit flush against the bottom of the drain pan and/or floor. Hold the filter in place, stretch the filter clip over the overlapped joint and hook in place (see Figure 6).

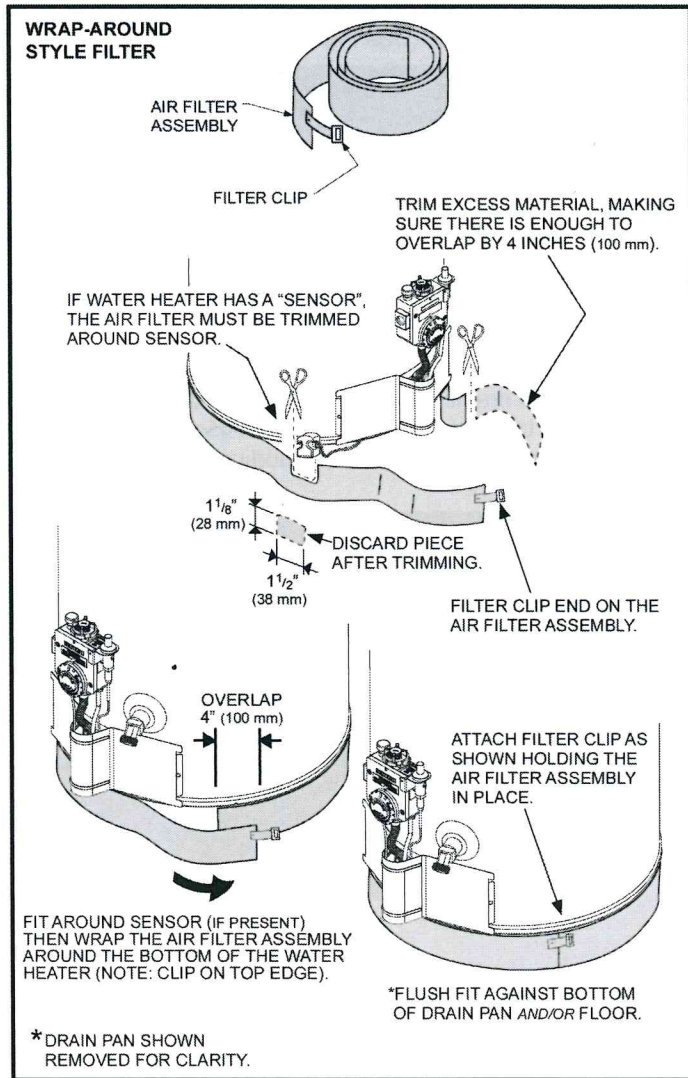

Figure 6

LIGHTING THE WATER HEATER:

- Follow the Lighting Instructions on the front of the water heater to light the unit. Once lit, verify proper operation and reattach the outer door.
- If the pilot won't light after repeated attempts, a service technician may be needed to perform a more thorough cleaning or to check for other issues. If you have questions, contact Residential Technical Assistance. The toll free number can be found in your manual or on the water heater's label.

CLEANING THE WRAP-AROUND FILTER:

- Periodically check the wrap-around filter for any dust/debris buildup on the filter screen. NOTE: If the installation environment is prone to excessive dust/debris, such as a laundry room, it may be necessary to inspect the wrap around filter at least once a month.
- The filter can be cleaned using a vacuum (See Figure 7). It is not necessary to remove the filter to clean the back sections.

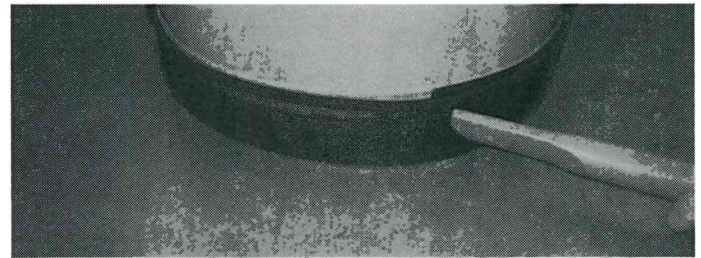

Figure 7

- Check the filter at least every three months and clean as necessary. Because the amount of dust and lint in the air can vary, your filter may need to be inspected/cleaned more often. In some instances, the filter may need to be removed and washed using mild hand soap and water to remove any oily residue. After washing allow to dry and properly reinstall.

NEVER OPERATE THE WATER HEATER WITHOUT A CLEAN AIR FILTER.

ADVANCED CLEANING INSTRUCTIONS

IMPORTANT: For correct water heater operation, it is essential that the advanced cleaning procedure be performed properly. If you lack the necessary skills to properly perform the advanced cleaning, you should not proceed, but get help from a qualified person.

CLEANING THE COMBUSTION CHAMBER:

1. Turn the water heater gas control knob to "off" and allow the burner area to cool completely, approximately 15 minutes, see Figure 8.

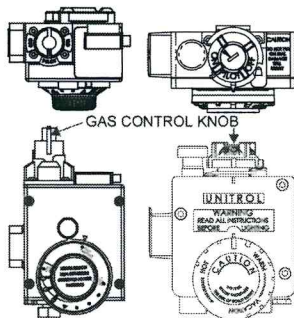

Figure 8

2. Turn off the supply gas at the supply gas line if applicable.
3. Remove the outer door from around the burner tubing at the base of the water heater. Disconnect the three connections from the bottom of the gas control valve/thermostat, being careful to note their location, see Figure 9.

⚠ WARNING!

Do not bend the gas control valve/thermostat connections too far; doing so may result in damage.

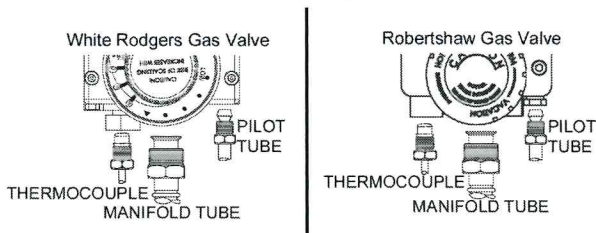

Figure 9

4. White-Rodgers Gas Control Valve/Thermostat: Remove the Piezo igniter (with the orange wire) from the gas valve by sliding it back toward the tank (leave the orange wire in the inner door assembly). Robertshaw Gas Control Valve/Thermostat: Disconnect the igniter wire at the base of igniter button.

5. Remove the 3/8" manifold door nuts, holding the inner door and white gasket in place, see Figure 10.

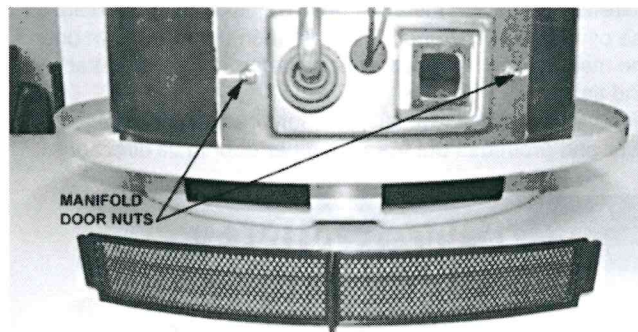

Figure 10

6. Carefully remove the burner from the combustion chamber. Scale or other materials may have collected on the top of the main burner; try not to dump any debris off of the burner until it and the inner door have been removed from the heater. **TAKE CARE NOT TO DAMAGE THE WHITE GASKET ON THE INSIDE OF THE INNER DOOR.**
7. Inspect the radiation shield (thin circular metal sheet under the burner and above the flame arrestor), see Figure 11. If any of the sides of the radiation shield are touching the base (disrupting air flow), install 1/2-inch high feet under the radiation shield. To obtain the feet free of charge, contact Residential Technical Assistance referencing the number in your manual.

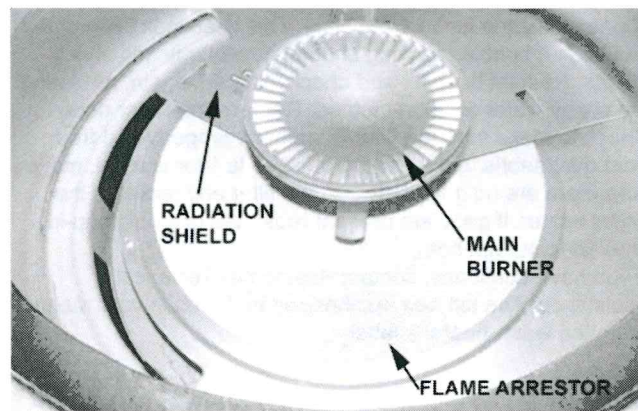

Figure 11

8. Vacuum the main assembly and pilot burner assembly. Then vacuum the top of the radiation shield located inside the burner chamber. **IMPORTANT: DO NOT** use the flexible cleaning brush provided with this kit to clean the top of the flame arrestor. It may be used to clean only the bottom of the flame arrestor. Use a soft bristle brush such as a paint brush or compressed air to dislodge any dust/debris from the inside of the combustion chamber and exposed section of the flame arrestor. Remove any collected dust/debris using the vacuum. **DO NOT** use any hard bristle brush or any other cleaning equipment that may damage the flame arrestor.

9. Re-insert the burner taking care that the main burner tube is seated in the burner positioning bracket.
10. Carefully reposition the inner door w/gasket over the bolts on the combustion chamber. Do not tighten the nuts down until the main burner, pilot burner, and thermocouple are attached and tightened.
11. Make sure that the white fibrous door gasket is not folded over and protrudes out from the inner door in all directions.

WARNING

Fire and Explosion Hazard



- Tighten both manifold door nuts securely.
- Remove any debris between inner door and combustion chamber.
- Replace viewport if glass is missing or damaged.
- Replace door gasket if damaged.

Failure to do so can result in death, explosion or fire.

12. Then tighten the 3/8" nuts to hold the inner door in place. Check the gas connections for proper fitting and then light the pilot, following the directions on the side of the heater.
13. Once the pilot is lit, turn the valve to the "ON" position and ignite the main flame. Brush soapy water on the gas connections and look for bubbling. This is an indication of a gas leak. If bubbles appear, shut off gas supply and check fittings. Re-light the pilot and check for leaks again, repeating the soapy water solution method. Replace the outer door.
14. Check to make sure the filter is installed properly and free from dust/debris. If the wrap-around style filter is used, make sure there are no gaps between the filter and jacket of the water heater. If gaps are present reuse the original snap-in style filter, but not both.
15. If you have questions, contact Residential Technical Assistance. The toll free number can be found in your manual or on the water heater's label.

Technical Bulletin

Subject: Installation Troubleshooting and Solutions

Models Affected: Atmospherically Vented Flammable Vapor Ignition Resistant (FVIR) Gas Water Heaters

With the new safety standards that have mandated FVIR (Flammable Vapor Ignition Resistant) water heaters, it is important for you (our customers and service technicians) to be able to easily diagnose and implement solutions that will take care of operational problems with these types of water heaters. This bulletin is intended to help you avoid typical installation issues with the water heater or the environment in which it's installed, and to help you understand what to do when you are trying to solve a problem.

The pilot thermocouple used in FVIR water heaters includes a TCO (temperature cutoff) switch. The TCO is an automatically resettable temperature switch that opens the thermocouple circuit if the water heater is not receiving adequate combustion air or the combustion chamber temperature exceeds the cutoff limit of the TCO switch. Let's examine the reasons the TCO switch in your thermocouple is being activated:

1. **The installation environment may be dirty.** The flame arrestor (ceramic plate) in the bottom of the combustion chamber is designed to allow combustion air to flow into the chamber and prevent the burner or pilot flame from igniting flammable vapors that may be present outside your water heater. In some cases, the flame arrestor can become restricted. When this happens, the burner flame will become lazy and overheat the combustion chamber causing the TCO switch to trip. To correct this and improve the environmental condition:

Check the external lint/dust filter screen at the bottom of the heater. If it has a build up of dust, lint, etc., remove the screen and clean with a vacuum or clear water. Next, check the flame arrestor (ceramic plate) in the bottom of the combustion chamber for any dust, lint, etc., that may have accumulated on the flame arrestor. Clean the flame arrestor using a vacuum, Swiffer® or soft brush to clean the holes in the flame arrestor. After cleaning, reinsert the external lint/dust filter screen (noting directional arrows ↑ imprinted on the outside tabs) with the arrows pointing up towards the top of the heater. If you have questions and for detailed cleaning instructions, contact Residential Technical Assistance referencing the number in your manual.

NOTE: If the original filter screen is missing or damaged, or you have an installation that frequently gets lint or dust buildup, we recommend the installation of a larger capacity filter screen. If you have questions, contact Residential Technical Assistance referencing the number in your manual.

2. **Temperature conditions exceed the TCO switch cutoff limit.** Water heaters installed in unconditioned spaces (such as garage or attic) can be subjected to exceedingly high ambient temperatures. These conditions can create operational conditions concerning the draft and pilot burner oxygen availability that may cause the TCO switch to activate or the pilot flame to fall off the thermocouple or extinguish. If your water heater is in an area where ambient temperatures exceed 115° F (e.g. attic, garage that is kept closed, unconditioned space, etc.) contact Residential Technical Assistance. Refer to the phone number found in your installation manual.
3. **The water heater may be starved for combustion air.** This causes the burner flame to get lazy and waver around in the combustion chamber, causing the TCO switch to trip. Here are the things to check for and correct:
 - a. The water heater may be located in a closet or space that does not have openings for combustion air to get to the water heater. Openings in the closet must be provided per the installation instructions, which tell you how much open area you need. **IMPORTANT:** The instructions only cover the needs of the water heater. The air requirements of all gas-fired or air-consuming appliances in the closet or space must also be considered. Don't forget an electric dryer, it also consumes air.
 - b. The openings in the closet are smaller than what is needed to supply adequate combustion air. Review the installation instructions and information as noted in (a) above.
 - c. The water heater may be installed in a utility room or closet along with a furnace or air handler, with a return air duct that has not been attached, or it may have leaks that are not sealed. When this condition exists, the return air system creates a significant negative pressure on the installed

space and significant down draft of the flue occurs at the water heater. Even if the utility room or closet has a door with louvers in it, a negative pressure may still exist. (When checking, be sure the furnace or air handler is ON and the doors are closed). When a down draft is created, the combustion products from the water heater can no longer exit up through the vent system. The flame inside the water heater will become lazy and wander around, causing the TCO switch to trip. If you can't fix the problem, notify a water heater service organization. **THIS IS A SAFETY ISSUE AND THIS CONDITION MUST BE FIXED** by having the return air duct system corrected immediately. Failure to do so could result in property damage, serious personal injury or death due to fire or carbon monoxide poisoning.

4. **There may not be a draft at the water heater draft hood.** With the water heater operating for 3 to 5 minutes, check for draft at the inlet to the draft hood with a match or a small amount of smoke. Remember, when checking, be sure all appliances in the installed space are on and the doors are closed. If there is no draft, and you have ruled out or corrected items a, b and c above, check the vent system for restrictions or obstructions. Correct and recheck for draft. You should also check the vent termination to be sure it is the correct height when it exits the home or structure. Refer to local code or the National Fuel Gas Code (ANSI Z223.1/NFPA 54 current edition) for how to evaluate this. Correct the vent height if needed and re-check the draft.
5. **A flammable vapor incident has occurred.** Of course, our desire to reduce the likelihood of a flammable vapor incident is the main reason that the new technology has entered the marketplace. If a Flammable Vapor Incident occurs, immediately have the water heater inspected by a licensed service technician. We will request that the unit be returned to us.